

Manufacturer's Declaration

This product is intended for installation in a machine or system, based on the machine directive 2006/42/EC. It is forbidden to start use of the product until the machine or system into which it should be built is operating in accordance with the EC directives.

The product corresponds to the low voltage directive 2006/95/EC.

The product corresponds to the EMC directive 2004/108/EC.

Safety Regulations Danger!



To prevent injury or damage, only professionals and specialists should work on the devices, following the relevant standards and directives. Please read the Installation and Operational Instructions carefully before installation and initial operation of the device.

- Electrical devices cannot be guaranteed fail-safe.
- Only work on this device when it is de-energised. Protect against inadvertent switch-on.
- Voltages of up to 250 VAC can be applied to terminals 11 – 12 – 14.



Warning:

Without a conformity inspection, this product is not suitable for areas where there is a high danger of explosion. This statement is based on the directive 94/9/EC (ATEX directive).

Application

This unit is used to monitor, control and to signal overload on pneumatically adjustable overload clutches with switching functions.

Function

The EAS®-Sp control unit monitors the switching condition of the clutch and emits a signal when the set torque is exceeded. It controls pneumatic valves, which are used to lock or to open the compressed air supply or to switch from engagement pressure 2 to torque pressure 1.

Transfer valve opens or closes the compressed air supply to the clutch; connection V2a/V2b

Pressure valve switches over between engagement pressure 2 and torque pressure 1; connection V1a/V1b.

Both connections are resistant against short-circuiting.

Electrical Connection

24 VDC/Gnd	+24 VDC input voltage Please Observe: Installed protection against incorrect polarity! To set up the voltage supply in the EAS®-Sp control unit, the correct connection voltage polarity is necessary.
ON	Start button / (+) connection for SP control.
OFF	Stop button / (+) connection for SP control
Gnd 1	(-) Connection for SP control
End	Limit switch signal
Gnd 2	(-) Connection for limit switch
12 V	(+) Output voltage for ON/OFF contacts and limit switch
V1a/V1b	Pressure valve 24 VDC
V2a/V2b	Transfer valve 24 VDC
14 – 11 – 12	Overload signalling relay , free nc turnover contacts, max. contact load 250 VAC/10 A



Please Observe! Do not apply any external voltage to the 12 V terminal.



Dimension (mm)

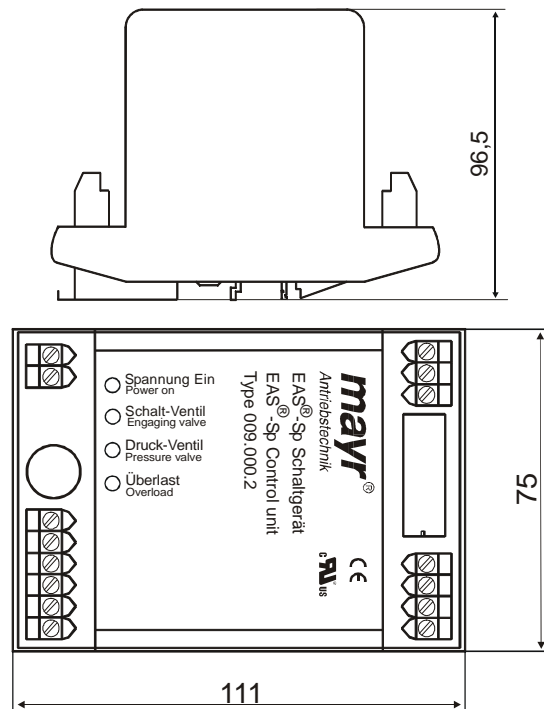

Functional Description

Function	Functional sequence
1 Switch on the 24 VDC input voltage	<ul style="list-style-type: none"> LED "Voltage ON" lights up green Signalling relay is energised, contacts 11 – 12 closed (SP control unit is energised and shows operating function)
2 Start (close ON contact)	<ul style="list-style-type: none"> LED "Voltage ON" lights up green LED "Transfer valve" lights up green LED "Pressure valve" lights up yellow The transfer valve is energised and opens the compressed air supply The pressure valve is energised and opens the engagement pressure 2 The clutch engages After engagement time t_k switch over to torque pressure 1. The LED pressure valve is extinguished and the signalling relay remains energised
3 Stop (open OFF contact)	<ul style="list-style-type: none"> LED "Voltage ON" lights up green The transfer valve is de-energised and closes the compressed air supply The clutch disengages The signalling relay remains energised
4 Overload	<ul style="list-style-type: none"> The clutch disengages LED "Voltage ON" lights up green LED "Overload" lights up red The transfer valve is de-energised and closes the compressed air supply The signalling relay is de-energised, contacts 11 – 14 closed (SP control unit is de-energised or gives an overload signal)
5 Reset via Start (1x) or Stop	<ul style="list-style-type: none"> LED "Overload" is extinguished Continue with Start Warning: First clear overload! <p>To reset the short-circuit monitoring: *switch off the mains voltage *clear the short circuit *switch on the mains voltage, then continue with "Start"...</p>

Functional Sequence

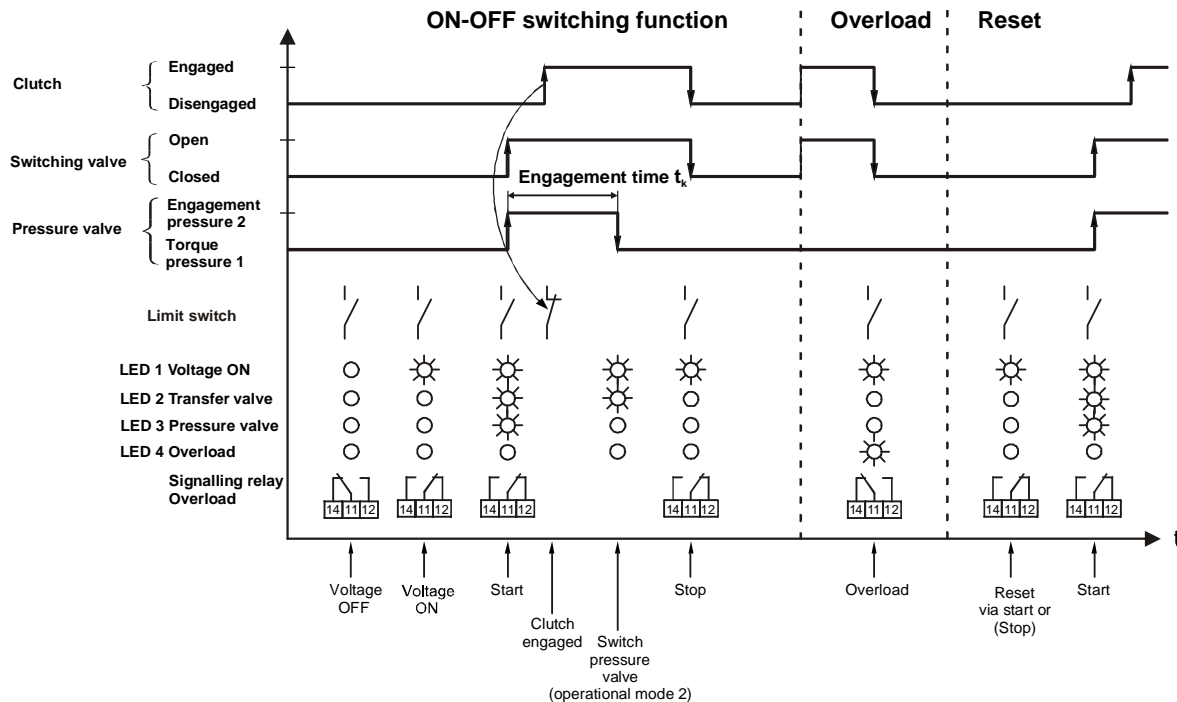

Adjustments

Start - Operation

- 3 2 1
- Single start (Manufacturer-side setting)
- Multi-start

Engagement time with single start

- 0 - 30 s (Manufacturer-side setting)
- 0 - 5 mins.

Engagement time with multi-start

- 0 - 30 s (Manufacturer-side setting)
- 10 s

Operational mode

- 2 (Manufacturer-side setting)
- 1

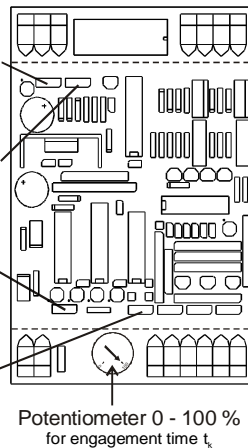

Please Observe! To avoid disorders or malfunctions, the operational modes are to be observed before making adjustments.

Engagement Time t_k

Adjustments of the engagement time t_k are to be carried out using the external potentiometer 0–100 %. **Adjustment of the engagement times for the following operational conditions:**

1. **Single start** (manufacturer-side setting)
Coding bridge: "Engagement time for single start" (Manufacturer-side setting) 0–30 s (for speeds >2 rpm)
Changing the coding: 0–5 mins. (for speeds <2 rpm)
2. **Multi-start** (by changing the settings)
 - a. **Single start operation (for first impulse start)**
Coding bridge: "Engagement time for single start" (Manufacturer-side setting) 0–30 s
Changing the coding: 0–5 mins.
 - b. **Multi-start operation (second and additional impulses)**
(Manufacturer-side setting) 0–30 s
Changing the coding: 10 s

Operational Mode 1 (Please observe the settings)

Switch over from engagement pressure 2 to torque pressure 1, when the clutch is engaged and the limit switch is actuated. The remaining engagement time is set to zero.

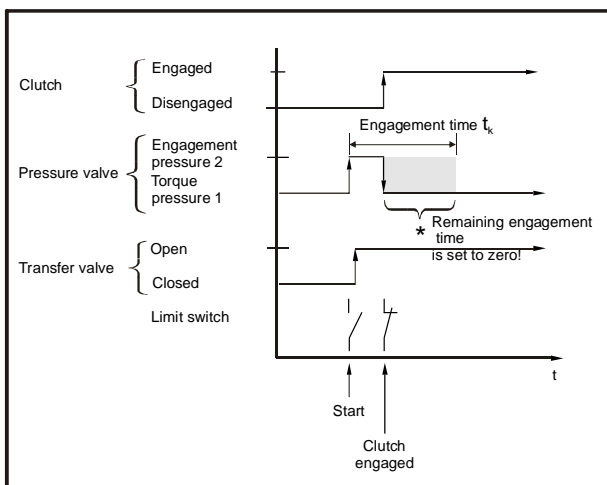

Operational Mode 2 (Manufacturer-side setting)

Switch over from engagement pressure 2 to torque pressure 1 when the engagement time t_k has passed and the clutch remains engaged.



Please Observe! Clutch-ratchetting during the engagement time t_k causes disconnection of the clutch and emission of an overload signal.

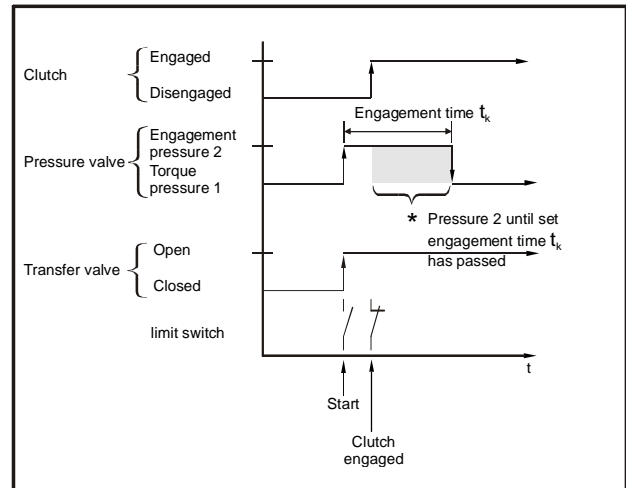

Multi-start (Please observe the settings)

The multi-start allows repetition of engagement pressure 2 switch-on during functional operation. Application possibilities in operational modes 1 or 2 and only with the 2-contact functional control.

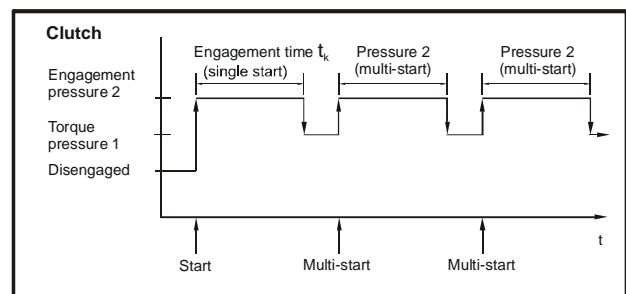

Installation

The unit is installed using a snap fastener attached to the housing, which can be attached to all DIN EN mounting rails.



Power connections are to be laid interference-free! The control wires (ON – OFF – Gnd 1 – End – Gnd 2 – 12 V) are to be laid separately and at a sufficient distance from the high voltage current or pulsating wires (PE / L1 / N).

Connection Example

Control elements / Control functions

Application	Function
	2 contacts Start: close ON contact Stop: open OFF-contact
	SP control Start: +24 VDC Stop: 0 VDC SP control 10–30 VDC
	1 contact Start: close contact Stop: open contact

Limit switch (monitoring)

Application	Function
	1 contact Clutch engaged: Contact closed Clutch disengaged: Contact open
	SP control Engaged: +24 VDC Disengaged: 0 VDC SP control 10–30 VDC
	PNP-NC contact Clutch engaged: Sensor undamped Clutch disengaged: Sensor damped PNP-NC contact: 3 Lead sensors, 10–30 VDC

Connection Example

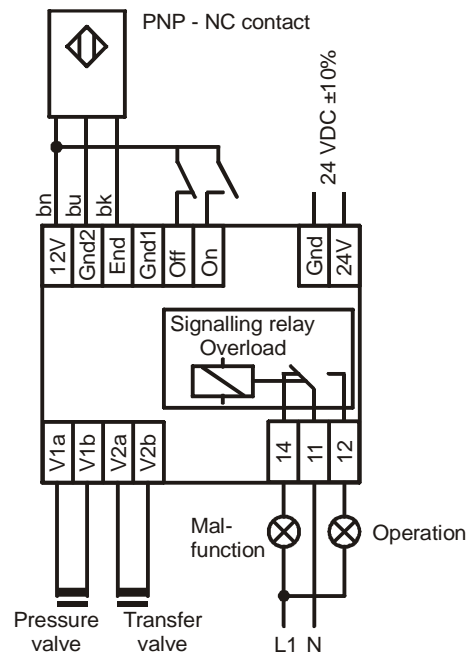

Technical Data

Input voltage	+24 VDC, +/- 10 %
Connection pressure valve	+24 VDC/0,5 A., resistant against short circuits
Connection transfer valve	+24 VDC/0,5 A., resistant against short circuits
Current consumption	max. 1 A/100 % ED
No-load supply power	<1 W
Protection	IP 20
Operating temperature	0 up to +50 °C
Storage temperature	- 20 up to +70 °C
Max. clampable conductor cross section	0,14-2,5 mm ² / AWG 26-14
Weight	210 g
Overload signalling relay	free nc switching contact, max. contact load 250 VAC/10 A
Conformity markings:	UL-Standard UL 508 CSA-Standard C22.2 No. 14-M91
Short circuit resistant coil connections	If a short circuit occur, the electronic monitoring registers this and switches off the affected coil voltage between the coil connections V1a and V1b or V2a and V2b.



Please Observe! The customer is responsible for providing the input voltage-side protection fuse.



Warning! No overload status signal will be emitted if the limit switch is not installed according to the regulations.

Installation in Accordance with EMC

The described measure for compliance with the EMC directive has been tested under laboratory conditions. Should deviations occur, it cannot automatically be transferred bindingly to the state of a machine or system. The test includes the individual components *mayr*[®]-EAS[®]-Sp control unit and magnetic valve and is valid for an input voltage of 24 VDC.

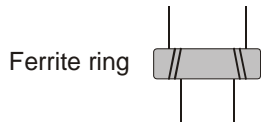

The voltage supply line must be max. 3m long. The rest of the lines must be max. 30m long.

Measures

- Installation of a ferrite ring (e.g. Würth 74270112) with 3 feedthroughs in the control line.

Please Observe!

- Mount the ferrite ring directly onto the EAS[®]-Sp control unit!
- Keep the feed lines short, no formation of rings or loops, avoid antenna effects!
- Lay power wires that are subject to interferences (e.g. frequency converters, power converters, ...) separate from control wires and EAS[®]-Sp control unit wires!
- If the device is operated using a frequency converter, please make sure that the frequency converter is installed in accordance with the EMC directive!

Standards

EMC test

DIN EN 61000-6-2:2006-03

Interference resistance